

150 mm Quad Gutter external bracket (Spike/Nail Bracket)

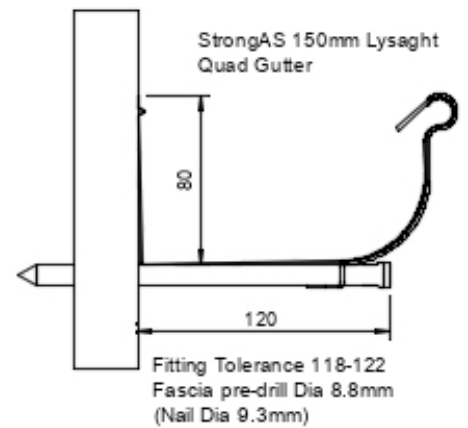

Note:
If unsure on the fitting tolerance for the 150mm bracket choose 122mm this can be adjusted later.

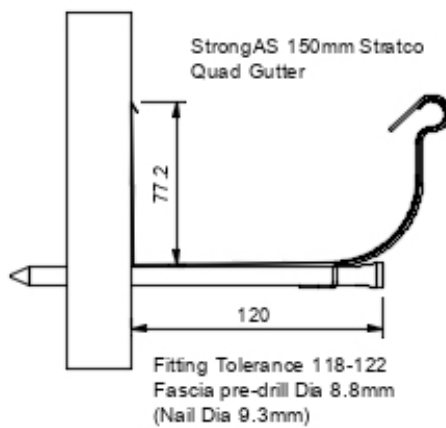
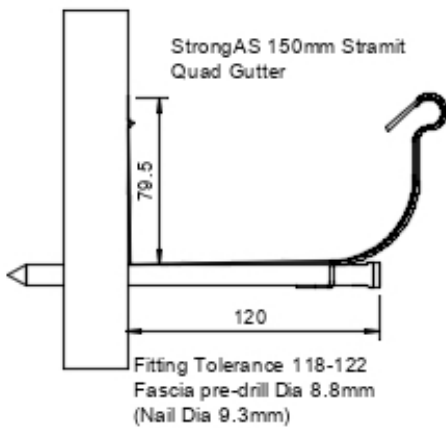
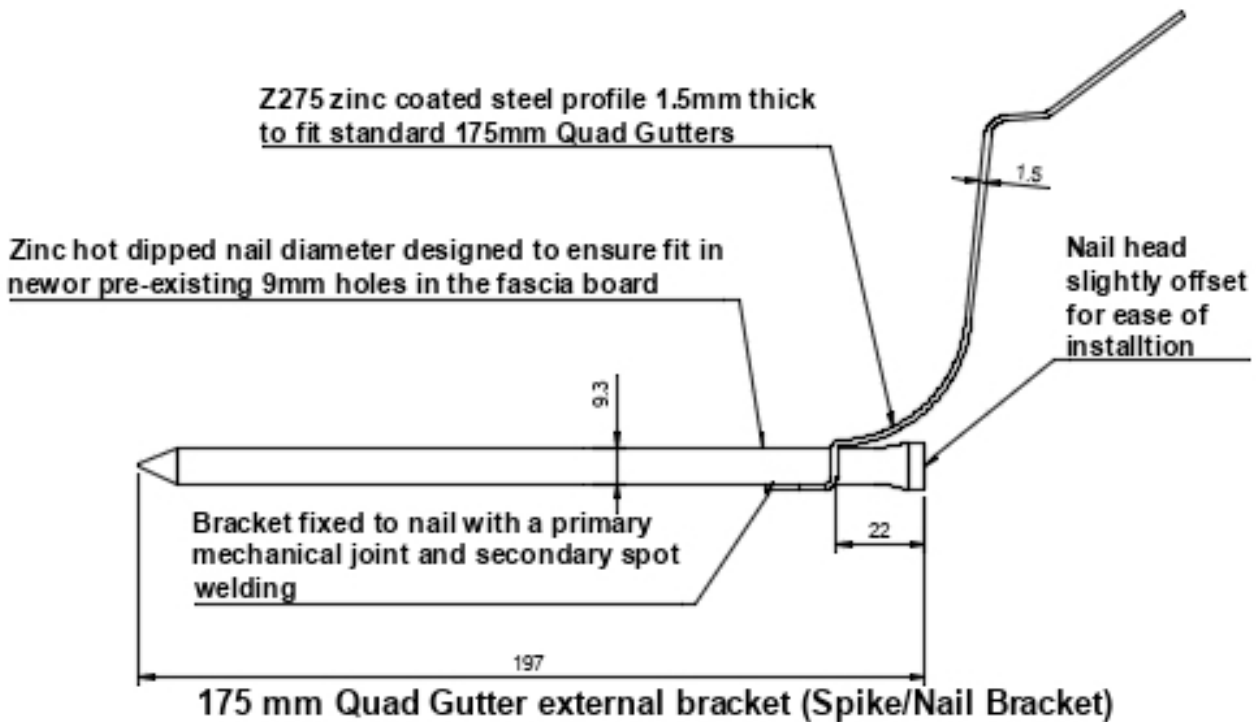

Note: Gutter widths can vary slightly across manufacturers, check the bracket against your chosen gutter profile before deciding on a dimension from the fitting tolerance. If unsure choose 156mm for the 175 bracket as this can be adjusted later.

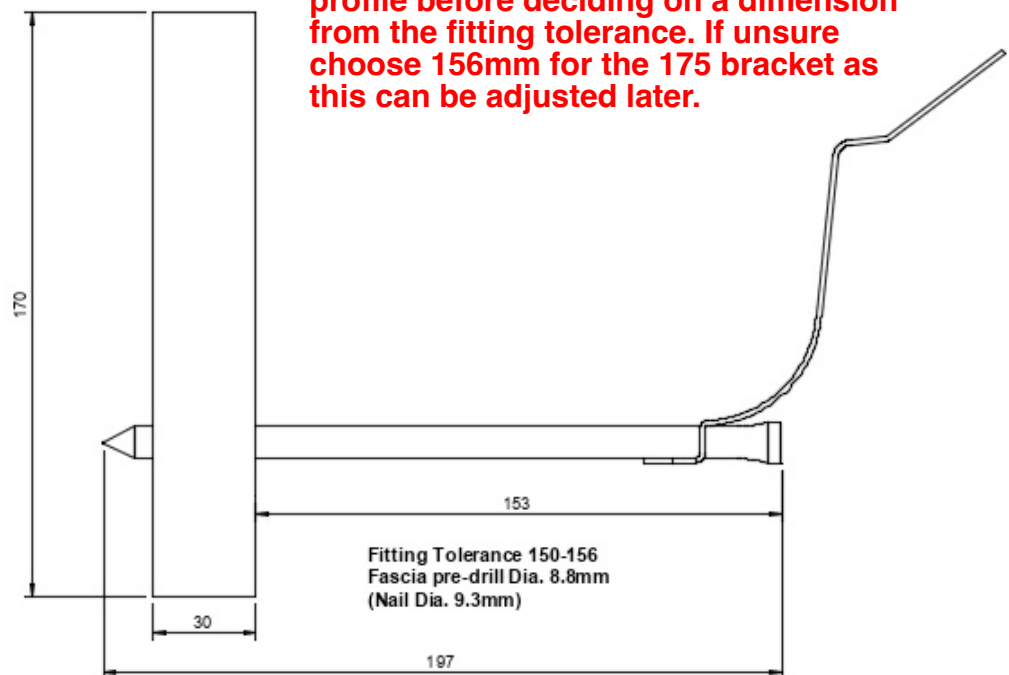

NOTES:

1. Install brackets at the high and low points according to the desired fall
2. Pre-drill square to the horizontal axis but slightly point down so when the spike /nail is installed the head of the nail is, slightly, pointed up. This accounts for any sag in the gutter once installed
3. Strong AS can't guarantee the condition of the fascia board as to the vertical face or rigidity of the material
4. Run a string line between the high and low points and mark off the intermediary positions at the face of the fascia board
5. Optionally, once the brackets are installed run a string line from the nail heads of the high and low points to check that the intermediary brackets are nominally in line, very slight adjustments can be made by bending the nail in the fascia board.